



A SilverLeaf Design LLC Company

**KROY**

*Sign Systems*

## MOLDED SIGN FRAMES

Molded sign frames are a versatile, durable and economical sign system. Designed for interior and exterior sign applications, these UV resistant, injection molded sign frames are uniquely engineered for changeable or permanent text messages, graphics and ADA sign inserts. With an assortment of sign frames and graphic insert materials available, informational and directional signs are functional and flexible in any facility.

Molded sign frames are available in assorted sizes and colors. Choose radius or square corner profiles in six standard colors. Kroy colors are conveniently stocked for quick delivery. Custom colors are also available. Molded sign frames and inserts can be color matched and finished to your specification.

Sign message inserts are interchangeable using stock polystyrene inserts, custom laminate inserts, digitally printed inserts or tactile faceplates with raised graphics. Adhesive-backed, ready-to-apply vinyl graphics are applied to polystyrene inserts. Digitally printed inserts are created using four color ink jet technology. A non-glare faceplate protects the insert and graphics. These options provide designers and facility planners with greater control and flexibility while maintaining the functionality of individual signs.

Kroy Sign Systems utilizes an advanced photopolymer process, producing a clear acrylic faceplate with 1/32" raised text, pictogram and Grade II Braille. Tactile faceplates are designed to meet ADAAG (Americans with Disabilities Act Accessibility Guidelines) and are manufactured to match specifications provided by Architects, Designers or any project specifier.

For more information on this or other Kroy Sign products, call 1-800-950-5769, send us an email or visit us on the web.

signs@kroysignsystems.com • www.kroysignsystems.com

*Quality*



*Service*



*Innovation*



*Esthetics*



# MOLDED SIGN FRAMES

## Specification Data

### 1 Frame

Injection molded high impact polystyrene plastic, UV resistant and surface textured to Rawal 6623 finish. Includes key holes for screw installation.

### 2 Lens Options

(**Standard**) 1/8" thick high impact clear polystyrene lens with a non glare surface  
 (**Option 1**) 1/16" polycarbonate lens  
 (**Option 2**) 1/16" non glare clear acrylic lens with raised photopolymer text and Grade II Braille.  
 (**Option 3**) Surface painted ultra thin steel tactile panel with raised text and Grade II Braille.  
 (**Option 4**) 1/8" non glare clear acrylic with permanently bonded solid color engraving material text and graphics and 1/16" clear acrylic Raster™ Braille.

### 3 Insert

.020" thick polystyrene insert with surface applied matte vinyl graphics. Optional digitally printed color insert replaces polystyrene insert.

### 4 Colors

Frames: Stocked in black, grey, darkgrey, white, brown & beige. Custom color available by request.

Inserts: Kroy's styrene insert colors from literature part #0090508 or finished to match customer specified color.

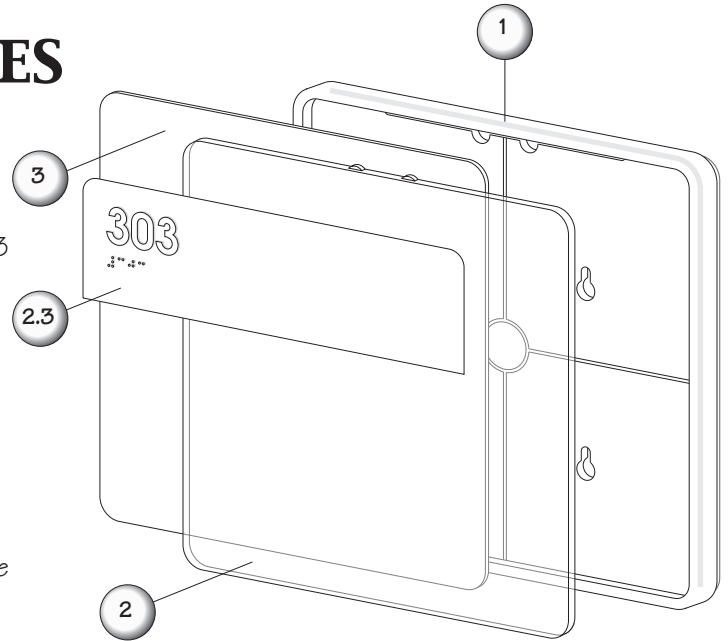

### Corner Profile

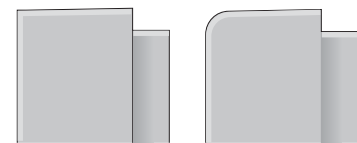

Square

Radius

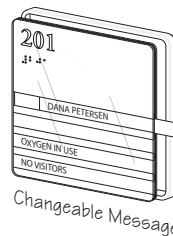

Changeable Message



Conference Room

- Raised tactile text and Grade II Braille complies with Americans with Disabilities Act (ADA) guidelines.
- High impact plastic frames are resistant to vandalism.
- Add a logo to strengthen company identity.
- Interchangeable styrene, laminate or digitally printed inserts provide quick, simple and inexpensive sign updates
- Include changeable message inserts or a conference room slider for tenant/room status.

6 x 12	6 x 6	8 x 8	8 x 8 cm, 4-slot	6 x 6 cm, 4-slot	8 x 8 conf. rm.
12 x 12	4 x 4	4 x 8	8 x 8 cm, 2-slot	6 x 6 cm, 2-slot	4 x 8 conf. rm.
	1.5 x 4	1.5 x 8		6 x 6 conf. rm.	1.5 x 8 conf. rm.

### Summary: 2010 ADA Standards for Accessible Design

Letters and numerals shall be raised 1/32" upper case sans serif type and shall be accompanied with Grade II Braille. Raised characters shall be at least 5/8" high, but no higher than 2". Pictograms shall be accompanied by the equivalent verbal descriptions placed directly below the pictograms. The border dimensions for the pictogram shall only be 6" in height. The characters and background of sign shall be eggshell, matte or other non-glare finish. Characters and symbols shall contrast with their background - either light characters on a dark background or dark characters on a light background.